

**GAMS**  
**MANUAL**  
**OF**  
**MOTOR**  
**SPORT**

with 1983 National Competition Rules

## Part 2—General Requirements of Automobiles

### 1. ALL AUTOMOBILES SHALL, OF NECESSITY, IN ALL COMPETITIONS:

- .1 Comply with the definition of an automobile;
- .2 be fitted with some form of protection between engine and driver's compartment suitable and sufficient in the case of fire for preventing the passage of flame;
- .3 be so constructed that the driver is protected from the entry of foreign matter into the driving compartment from the road/or road wheels;
- .4 be equipped with a transmission system so arranged that—  
 the propeller shaft and universal or carden joints, if passing through or beneath the driver/passenger compartment, shall be under the floorboards, or fitted in tubes or casings; such floorboards, tubes or casings shall not be of a temporary nature, but shall be joined together and firmly fixed to the coachwork or chassis;  
 any chains used in the transmission of power or for driving any auxiliary component, shall be effectively guarded;
- .5 be fitted so that all fuel tanks are vented externally to the bodywork.
- .6 not be equipped with any device providing for radio communication between the vehicle whilst in motion and pit and service crews, save in races of 250 km. length or more, and in special stage rallies;
- .7 if not registered for use on public roads, have any steering column locking device removed;
- .8 if required to be fitted with roll-over protection by the provision of these rules, be equipped with such protection only in accordance with the provisions of Part 10 of this Appendix.

### 2. ALL AUTOMOBILES SHALL, OF NECESSITY, IN ALL SPEED EVENTS:

- .1 (if fitted with rear hinged bonnets and/or panels) be fitted with at least two independent fastening systems, of adequate strength and limited extensibility, which simultaneously hold the bonnets or panels closed;
- .2 (if fitted with crankcase breather/s discharging to atmosphere) have fitted to such breather/s an oil-trap container (which must be empty at the start of the competition) of at least two litres (for cars of under 2000 cc) or three litres (for cars of over 2000 cc) except in Autocross, Rallycross and other events on unsealed surfaces, save however that Supplementary Regulations may require fitment for any particular event;
- .3 (other than one-car-at-a-time closed speed events) be fitted with a roll bar or roll cage and safety harness complying with such specifications as are determined by CAMS from time to time. (See Parts 9 and 10.)  
 (Note: structurally unmodified fixed roof closed cars may compete in events other than National Open Race Meetings without roll-over protection.)
- .4 be fitted with a fire extinguisher or fire extinguishing system in working order and of a type and capacity as specified in Part 8 of this Appendix as is appropriate;
- .5 be so constructed that, in the event of any breakage, the tailshaft, its components or mountings, shall be effectively prevented from striking the ground;
- .6 be fitted with wheels which meet the requirements of specifications determined by CAMS from time to time (see Part 5);

- .7 be so constructed that any aerodynamic device fitted shall be in accordance with specifications determined by CAMS from time to time (see Part 6);
- .8 comply with any Supplementary Regulations for a specific event which require the fitment of locking or wiring devices adequate for the prevention of any loosening of any oil drain plug.
- .9 be fitted with a scatter shield if required under the provisions of Part 13 of this Appendix.

Notwithstanding the above requirements, cars registered for road use shall not, when competing in one-car-at-a-time speed events, be required to comply with the provisions of sub-sections 2, 3, 5, 8 and 9 of this Section.

**3. ALL AUTOMOBILES OF THE 1ST CATEGORY SHALL, OF NECESSITY, IN ALL SPEED EVENTS, AND IN ADDITION TO THE PROVISIONS OF 2 ABOVE:**

- .1 if employing a battery electrical system, be provided with either an automatically or manually operated battery-circuit breaker or isolating switch. In the case of a manually operated device, it shall be accessible to the driver and to persons outside the car and shall be clearly identified by a 6-inch blue triangle on a white ground if necessary for contrast. The switch must be on the live side of the battery, and fitted in accordance with the switch manufacturer's directions. A clear indication of "off" and "on" positions must be marked adjacent to the relevant positions.
- .2 be equipped with a double circuit braking system so arranged that the pedal normally operates on the four road wheels, and in the event of leakage at any point in the braking system, the pedal shall still control two wheels on the same axle. Provided that in "straight-line" sprint events, and in events exclusively for historic or vintage cars, braking systems operating on two wheels of the same axle shall be acceptable;
- .3 be equipped with exhaust pipes, the orifices of which, when directed horizontally to the rear, must be between 300 mm and 600 mm above the ground, and may not protrude by more than 250 mm beyond the rearmost portion of the car;

**4. ALL AUTOMOBILES OF THE 2ND, 3RD AND 4TH CATEGORIES SHALL, OF NECESSITY, IN ALL SPEED EVENTS, AND IN ADDITION TO THE PROVISIONS OF 2 ABOVE:**

- .1 be equipped with an exhaust system, the outlet pipe/s of which shall be directed either rearwards or sideways. If rearwards, their orifices shall be between 100 mm and 450 mm above the ground, and they shall not protrude by more than 150 mm beyond the rear-most portion of the car. If they are directed sideways, their orifices must be located aft of a vertical plane passing through the midpoint of the wheel base. They may neither project in any way beyond the maximum width of coachwork nor terminate at a point more than 50 mm within the projected plan of the coachwork. Adequate protection shall be provided to prevent heated exhaust pipes from causing burns.
- .2 be fitted with an operable reverse gear;
- .3 be marked with a 150 mm blue triangular sign indicating the location of the battery;
- .4 be fitted with a windscreen in accordance with Part 3, Group A, or as may be required in Production Category;
- .5 be so equipped that under no circumstances is any part of the coachwork less

than 4 cm above the ground, the car being in normal trim with the driver on board.

**5. ALL AUTOMOBILES IN CIRCUIT RACES SHALL, OF NECESSITY, IN ADDITION TO THE PROVISIONS OF PRECEDING PARAGRAPHS 2, AND EITHER 3 OR 4, AS APPLICABLE:**

- .1 be fitted only with laminated glass in any glass windscreen;
- .2 be fitted with tyres which have not been retreaded, recapped, repaired or in any way reconditioned; if tubeless racing tyres, shall have been fitted only to suitable rims; if tubeless touring tyres, may be fitted only to rims classified as optimum sizes for the covers concerned (fitting of such tyres to so-called "permissible" or oversize rims is specifically prohibited); in all cases, shall be required to carry a manufacturer's speed rating appropriate to the type of automobile and competition concerned;
- .3 be fitted with bodywork which generally encloses (when viewed from above and each side) the chassis frame and basic mechanical elements, from the front of the automobile rearwards to the vertical plane immediately to the rear of the driver's seat. Provided that, in the case of a vehicle driven by a provisional licence holder, such further panel/s must be fitted as may be necessary to comply with the requirements of Part 11, Article 2;
- .4 be fitted with locking or wiring devices adequate to prevent the loosening of any oil drain-plug (Note: Supplementary Regulations for speed events may also require the fitment of such devices);
- .5 be fitted with at least two (2) rear vision mirrors, of which each must have a reflecting surface of at least 50 cm<sup>2</sup>, and provide an unobstructed view to the rear of the car, save that, in automobiles with close body-work (whether of sports or touring types), one such mirror shall be fitted internally and one externally.
- .6 be fitted with a fuel tank as specified in Part 14 of this Appendix as is appropriate.
- .7 be fitted with readily accessible towing eyes, having an internal diameter of 40 mm; one each forward of the front axle and rearwards of the rear axle.
- .8 be fitted with fuel lines only of metal, braided Neoprene, or other CAMS approved material.
- .9 In closed cars, have the driver's window fully open at all times during practice and racing.
- .10 In closed cars first registered with CAMS after 1st January 1980, and in which the relevant regulations permit the replacement of the driver's seat, be fitted only with such replacement seat which—
  - incorporates a head restraint
  - has no provision for mechanical adjustment of the rake of the squab
  - if the original seat mountings are not used, is mounted in four places using 100 mm x 45 mm plates, of thickness 6.4 mm aluminium or 4.6 mm steel, each attached by at least 2 bolts of 10 mm diameter or the approved equivalent thereof.

## 5th CATEGORY

## Historic Cars

## 1. PREAMBLE:

- .1 The following definitions and general requirements governing Historic cars are recorded to facilitate the organisation of competitions and meetings in which such cars are involved.
- .2 In addition to running each group separately—entries permitting—events combining Group J, K & L would be generally acceptable. Combining of Groups M & N with other Groups is permitted, subject to specific application to CAMS in each case. In all cases cars invited to participate should be in accord with the period of motor racing it intends to portray so far as their general appearance is concerned. Combinations of groups other than as indicated above is strongly discouraged, and CAMS reserves the right to disallow variations therefrom.
- .3 The express purpose of these regulations is to see that cars in the various groups compete in a condition, mechanically and visually, compatible with the period of racing being portrayed. "Updating", in whatever form, is not condoned. CAMS reserves the right to reject any vehicle which it considers not within the spirit of these regulations. Cars must conform with the appropriate Group date specification in concept and in detail. Where any doubt exists between Historic regulations and the original period specification, the latter will take precedence.
- .4 CAMS, in its absolute discretion, reserves the right to accept or reject any car for Historic classification. The issue of all Log Books must be firstly authorised by CAMS head office, and a general register of Historic cars in all groups will be maintained.  
Before commencing construction work, or before acquiring a car, owners must consult the Historic Eligibility Officer regarding eligibility of the said vehicle.
- .5 CAMS reserves the right to classify or re-classify a car to a category which in its absolute discretion CAMS believes it conceptually belongs having regard to Australian Motor Racing History.
- .6 CAMS may approve re-creation of significant cars which have been destroyed under the following conditions:
  - (i) There may be only one re-creation.
  - (ii) Approval of CAMS in principle must be sought prior to commencement of the project. It should be noted that this does not in itself guarantee the registration of the vehicle which shall always be the subject of inspection and approval when completed.
  - (iii) There must be justification for the project, i.e., it must be a significant car.
  - (iv) A faithful re-creation only will be considered.
- .7 Additional information and advice is provided in the Historic Racing Guide which is available from CAMS Offices.

## 2. GENERAL:

- .1 Cars in all groups—while competing in events specifically limited to such cars—are exempted from CAMS requirements in respect of fire extinguishing systems (but not fire extinguishers), scatter-shields, roll-bars, safety-

harness, minimum coachwork, towing eyes, and fire-walls (although the fitment of these devices is in some cases desirable), and safety fuel tanks.

- .2 Cars in Groups J, K and L shall generally not be bound by any regulation concerning self-starting devices, lights, road equipment or minimum or maximum dimensions or weights. However sports cars and sports racing cars in Groups L and M will be required to conform with the minimum requirements of Category 2, Group A, so far as electrical equipment is concerned.

All cars must comply with the appropriate provisions of Part 2 of Appendix C, except that cars which raced without bodywork in the respective group period are exempted from the requirements of Part 2, Par. 5(c) as regards bodywork.

3-wheel cars participating in events exclusively for Historic cars, are exempted from the requirements of Part 2, Par. 1.1.

## .3 Fuel

Cars in Group J, K, Lb and Lc have freedom to use any type of fuel. Cars categorized in Group La, M & N will normally be restricted to commercial fuel, as defined by CAMS; however provided that it can be demonstrated that the subject car used other than commercial fuel during the Group period, and subject to prior application to and approval of CAMS, alternative fuels may be permitted.

## .4 Suspension

Suspension media must remain unchanged in all groups from the specification evident during the applicable group period, excepting that with "new" Group J and K cars, the suspension medium shall be compatible with the group period portrayed. Fore and aft axle location may be improved in all groups.

## .5 Coachwork

In all groups, fibreglass panels are not normally permitted unless fitted as original equipment.

In production cars coachwork must be unmodified, all internal and external trim must be intact, except that carpeting, windscreen and bumpers may be removed and seats may be replaced by others of period and type appearance.

## .6 Induction System

Carburettors must be of the same make, type and number fitted (or as originally supplied in the case of Group LA cars) in the applicable Group period. Single choke carburettors may not be replaced by multiple choke units, but Venturi size may be varied. A supercharger or fuel injection system may be used only if original equipment (in the case of Group LA) or if used in the applicable Group period on the car in question (in the case of other Groups). Motor cycle engine cars originally using Amal carburettors may use Amal "concentric" Mark I carburettors.

## .7 Differential &amp; Rear Axle

The axle tube outers must be as original. The differential, carrier and axles are free.

## .8 Starter Motor

An electric starter motor may be fitted to any car.

## .9 Wheels and Tyres

- (a) If original wheels are not fitted, then the following minimum and maximum dimensions shall apply, unless there is evidence to establish beyond doubt that a car was otherwise equipped—

| Group | Non-original Wheels |               | Tyres           |
|-------|---------------------|---------------|-----------------|
|       | Minimum Diameter    | Maximum Width | *Minimum aspect |
| J     | 18"                 | 3.5"          | 70%             |
| K     | 16"                 | 4"            | 70%             |
| L/A   | orig. diam.         | 5"            | 70%             |
| L/B   | 15"                 | 5"            | 70%             |
| M     | 13"                 | 6"            | 60%             |
| N     | —                   | 6"            | — (see Group N) |

\*as determined by the Tyre & Rim Association Manual.

(b) Short life motor cycle and other untreaded racing tyres are prohibited being incompatible with the philosophy of Historic racing.

.10 Specific Components (*Conditions of use*)

|   | Production Cars   | Others   |
|---|---|--|
| Toothed belt drives   | only if original equipment  | only if used on subject car within group period  |
| Supercharging   |   |  |
| Electric fans   |   |  |
| "Rose"/Uniball joints   |   |  |
| Gear box  | original number of ratios   | number of ratios as in group period  |
| Brakes  | original system only<br><br>dual/tandem master cylinders may be fitted.<br>Mechanical to hydraulic conversion permitted.<br>NOTE: Period major brake components only may be used. | a system fitted to the subject car within group period                                 |
| Engine  | must retain cylinder block & heads of original design.  | must retain cylinder block & heads of specific design used in applicable Group period. |
| From 1 January 1984 it will not be permitted to increase the bore by more than 1.5 mm nor to vary the stroke of engine: | from original specification   | from specifications evident in the applicable Group period                             |

.11 Original style paintwork and livery is encouraged. No advertising matter is permitted unless evident in the applicable Group period (Groups J, K, L and M). Markings on Group N cars are as set out at sect. 6 of the Group N regulations.

.12 Nothing in the foregoing definitions shall affect any rights or powers conferred upon organisers or others by CAMS, in relation to the refusal of entries or exclusion of competitors.

.13 CAMS foreshadows the introduction, at some appropriate time, of Groups within this category for Production Sports Cars beyond 1960, and for Racing and Sports-racing Cars beyond 1965.

### 3. GROUPING:

#### Group J—Vintage Cars

- .1 Factory-built racing cars and sports cars, all constructed before December 31, 1930, or
- .2 Special racing cars and sports cars, all constructed at any time, employing primary, engine, transmission and chassis components, and modes of suspension, of cars constructed before December 31, 1930, in any combination.
- .3 Cars in this Group *only* shall be eligible for any prize or trophy to be awarded to a "Vintage" car.

A statement "Pre 1931, referred to as Vintage", should be included in programmes, above the list of entries of vehicles in this class.

#### Group K—Post Vintage Cars

- .1 Factory-built racing cars and sports cars, all constructed between December 31, 1930, and December 31, 1940, or
- .2 Special racing cars and sports cars all constructed at any time, employing primary, engine, transmission and chassis components, and modes of suspension of cars constructed before December 31, 1940 in any combination.
- .3 Cars in this Group *only* shall be eligible for any prize or trophy to be awarded to a "Post-Vintage" car.

A statement "Pre 1941, referred to as Post-Vintage" should be included in programmes, above the list of entries of vehicles in this class.

#### Group L—Historic Racing and Sports Cars (1940/60)

- .1 *Sub Group (a) Sports Cars* manufactured after December 31, 1940 but prior to December 31, 1960, employing original major engine, transmission, body, chassis and suspension components. Suspension shall remain unmodified from original specification, except that spring rates, ride height and damper setting may be altered. Lateral axle location may not be varied.
- .2 *Sub Group (b) Racing Cars and Sports Racing Cars* manufactured after December 31, 1940 but prior to December 31, 1960 employing original major engine, transmission, body, chassis and suspension components. Cars which have no competition history must have been completed in the Group period. Lateral axle location may not be varied.
- .3 *Sub Group (c) Sports Cars* manufactured after 31st December 1940 and prior to 31st December 1960, on which the mudguards and windscreen are readily removable, and on which they do not form an integral part of the main body may compete in stripped form as racing cars, or with equipment in situ, as sports cars.

Vehicles may vary from standard production form only in a manner which is consistent with retaining the "nature as road registered and road used vehicles. In particular, no change to track, wheelbase, engine position and suspension medium may be made. Engine, transmission and differential

should be of the type normally fitted to the model. Lateral axle location may not be varied. Cars in this sub-Group will normally compete with cars in sub-Group Lb.

- .4 Non-factory built cars in either sub group may be admitted after individual assessment.
- .5 The stroke of the engine may not be changed. The bore may be increased by up to 1.5 mm.

### Group M—Historic Racing and Sports Racing Cars (1961/65)

(Note: Production sports cars are not eligible in this Group.)

Racing cars, sports-racing cars and clubman cars manufactured after 1st January, 1961 and before 31st December, 1965, employing original engine, transmission, suspension and chassis components.

### Group N (Appendix J)—Saloon Cars (Pre 1965)

#### 1. ELIGIBILITY

- .1 The automobile must be a series production type saloon, manufactured prior to 31 December, 1964 of which 100 of the particular model must have been produced.
- .2 Cars shall compete in the following engine capacity classes:—
 

|                          |                               |
|--------------------------|-------------------------------|
| Class A—Over 3000 cc.    | Class E—1301 to 1600 cc.      |
| Class B—2601 to 3000 cc. | Class F—1001 to 1300 cc.      |
| Class C—2001 to 2600 cc. | Class G—Up to 1000 cc.        |
| Class D—1601 to 2000 cc. | (Classes may be amalgamated). |

#### 2. BODY

- .1 The body must be of a saloon (i.e.: “hard-top”) form, and must provide adequate normal seating accommodation for four adult persons or more.
- .2 Cars in the above-mentioned Classes A, B, C, D, and E must have four doors unless they have been homologated by the F.I.A. in a two-door version: cars in Classes F and G must have at least two doors.
- .3 The bodywork, body fittings and interior trim in its entirety must be as supplied by the manufacturer, except only that wheel naveplates may be removed, additional instruments fitted and the steering wheel replaced. Provided that the replacement wheel is not less than 380 mm in diameter, unless the original wheel was of a lesser diameter, in which case a replacement of at least equal diameter to the original is acceptable.
- .4 The use of undertrays, farings, etc., designed to improve the aero-dynamic form of the automobile shall not be permissible unless supplied as standard equipment.
- .5 Original seats may not be replaced with other seats. However, the driver’s seat may be padded to provide additional support.
- .6 Restoration of original trim is permitted, but should be as near as practicable to original specifications.

#### 3. PERMITTED MODIFICATIONS:

Mechanical modifications may be made, provided that the following restrictions are observed:—

- .1 The original type of cylinder-block and crankcase must be employed. The bore and stroke may be varied, provided that the cubic capacity of the engine remains within the same cubic capacity class as that within which the engine came as supplied by the manufacturer.
- .2 The original type of cylinder-head casting must be employed. The cylinder-head may be modified provided that such modifications is effected only by the removal of metal.
- .3 Forced induction is not permitted, unless such induction method is employed as standard on the make and model of car by the manufacturer concerned.
- .4 The original type of gearbox and rear-axle assemblies as supplied by the manufacturer for the make and model concerned shall be employed. The use of alternative ratios in the gearbox and back axle is permitted, provided that the components used are supplied by the manufacturer concerned as catalogued component parts. A limited slip differential may only be used if a catalogued component part for the make and model concerned, and of the original type. Locking of differentials by whatever means is not permitted.
- .5 The original type of suspension only shall be employed (e.g.: a semi-elliptic leaf-spring suspended live rear-axle may not be replaced by a coil-spring suspended De Dion type, and so on).
- .6 The original type of braking system shall be employed (e.g.: drum-brakes may not be replaced by disc-brakes). The major brake dimensions (i.e.: internal drum diameter and width) shall be identical with the dimensions of these components as supplied as original equipment by the manufacturer concerned. Provided that a total overall variation in the diameter of such drums of no more than 3 mm shall be permissible. Modifications to disc brakes are limited to the freedom to fit alternative calipers of a type available pre 1965. Dual circuit braking systems are permitted, as is installation of power brake assistance.
- .7 The wheels shall be either as supplied by the manufacturer or of a type approved by CAMS and which is in harmony with wheels used prior to 31st December, 1964. At all times the original wheel diameter shall be maintained, and the width of the rim may be increased by no more than 25 mm/1" over the original, subject to an absolute maximum width of 6". Tyres may not protrude outside the coach work, but otherwise track is free.
- .8 At all times, the original form of steering and suspension joints will be employed, and in particular, may not be replaced by “Uniball” or “Rose” type joints.
- .9 Dry sumping is not permitted, unless original equipment on the make and model concerned.
- .10 Tyres must be an approved type of radial or cross ply construction with a minimum aspect of ration 70%. Racing tyres are not permitted. A list of approved tyres is an Appendix to these Regulations and is available from CAMS upon request.
- .11 The radiator cooling fan may be removed; electrically powered fans are not permitted.

#### 4. SAFETY REQUIREMENTS:

- .1 Vehicles shall comply with all relevant requirements of Part 1 of Appendix C to the NCR’s.
- .2 A laminated windscreen is required in all vehicles. However, in the event that a laminated screen is unavailable, approval may be given on individual application for the fitment of a Lexan or Perspex windscreen.

**5. GENERAL**

- .1 The automobile shall be required to comply with such requirements of Appendix "C" as are applicable and not in conflict with this Appendix.
- .2 A high standard of presentation will be insisted upon at all times. Any vehicle considered to be of inappropriate standard will be summarily rejected.
- .3 At all times, the onus of proof of eligibility of the automobile and/or components, whether options or not, will be the responsibility of the owner, by way of homologation papers, parts manuals, workshop manuals etc. Additionally, in marginal cases, proof may be required to be produced to the effect that a vehicle of the same model was raced prior to December 1964.

**6. ADVERTISEMENTS ON AUTOMOBILES:**

No advertisement or trade sign will be distributed from or carried on any automobile in this category. Provided that this Rule shall not apply to the manufacturer's usual name plate, transfer or other device normally attached to, engraved or stamped on cars sold by them to the public. CAMS reserves the right to permit also the display, in neat, unobtrusive lettering, of the name of the entrant and/or the driver and/or the State of his origin on the scuttle or side of the car. No such sign shall in its entirety exceed 75 mm in height and 600 mm in length.

**7. SPIRIT OF REGULATIONS:**

It is emphasised that the purpose of this category of racing is to emulate, as far as is practicable, racing of saloon cars under Appendix "J" regulations which were current until 31st December, 1964. Over-restoration of vehicles, the use of technology, parts or equipment not available within the period in question is not within the spirit of these regulations; these regulations and any eligibility matters relating thereto shall be interpreted and applied in accordance with the spirit.

**5. GENERAL**

- .1 The automobile shall be required to comply with such requirements of Appendix "C" as are applicable and not in conflict with this Appendix.
- .2 A high standard of presentation will be insisted upon at all times. Any vehicle considered to be of inappropriate standard will be summarily rejected.
- .3 At all times, the onus of proof of eligibility of the automobile and/or components, whether options or not, will be the responsibility of the owner, by way of homologation papers, parts manuals, workshop manuals etc. Additionally, in marginal cases, proof may be required to be produced to the effect that a vehicle of the same model was raced prior to December 1964.

**6. ADVERTISEMENTS ON AUTOMOBILES:**

No advertisement or trade sign will be distributed from or carried on any automobile in this category. Provided that this Rule shall not apply to the manufacturer's usual name plate, transfer or other device normally attached to, engraved or stamped on cars sold by them to the public. CAMS reserves the right to permit also the display, in neat, unobtrusive lettering, of the name of the entrant and/or the driver and/or the State of his origin on the scuttle or side of the car. No such sign shall in its entirety exceed 75 mm in height and 600 mm in length.

**7. SPIRIT OF REGULATIONS:**

It is emphasised that the purpose of this category of racing is to emulate, as far as is practicable, racing of saloon cars under Appendix "J" regulations which were current until 31st December, 1964. Over-restoration of vehicles, the use of technology, parts or equipment not available within the period in question is not within the spirit of these regulations; these regulations and any eligibility matters relating thereto shall be interpreted and applied in accordance with the spirit.

## Part 4—Apparel

*Races, Speed Events & Off Road Events***1. HEADGEAR:**

It is compulsory, in all races and other speed events, that drivers wear helmets of a standard design, construction and fitting approved by CAMS.

The helmets acceptable by CAMS shall be required to comply with AS1698-1974.

Helmets not marked as complying with the above standard may be approved by CAMS under certain conditions.

"Balaclavas" are recommended (though not mandatory) for drivers, especially those with long hair and/or beards, as are face-masks.

Painting or use of solvents on helmets could be hazardous.

**2. GOGGLES:**

Goggles must be worn by drivers of open cars. Those with glass lenses of any kind are not acceptable. Lenses shall be of a plastic material, with high impact resistance, satisfactory optical qualities and complying with Australian Standard Specification AS1609-1974, and bearing either the SAA mark or the CAMS-approval mark.

*Races***3. CLOTHING:**

In all circuit races and practice therefor, all drivers shall be required to wear approved clothing as follows:

- (a) Overalls of an approved flame-resistant material, extending from wrists to neck to ankles; *together with*
- (b) Heat-resistant underwear, extending from wrists to neck to ankles, and of a woollen or such other material as may be specifically approved by CAMS, *and*
- (c) Socks of undyed wool or other flame retardent material, worn under flame resistant boots or shoes which completely enclose the feet. (Driving without such footwear is forbidden.)
- (d) Gloves of recognised flame retardent material.

No apparel of flammable material (e.g. nylon or similar synthetics) may be worn in any race.

**4. PIT CREW:**

All persons working on cars must wear shoes and socks, neck to ankle covering, and at least a short-sleeved shirt. On race day, pit crew must be neatly attired. Promoters are authorised to refuse entry to the pit area of people unsuitably dressed.

*Rallies***5.**

No person may compete in any rally of Australian Championship, International or special stage status unless wearing, in other than transport stages, a properly fastened helmet, complying with such specifications as CAMS may lay down for rallies.



**6.** No person may compete in any open rally or any rally timed to intervals of less than 1 minute unless wearing shoes & socks, a shirt with at least short sleeves, & clothing from neck to ankle.

**7.** It is strongly recommended that no apparel or flammable material (e.g. nylon or similar synthetics) be worn.

*All Events*

**8.** No driver shall participate in any competition unless wearing suitable and appropriate footwear. Prohibited are, for example, thongs, Roman sandals and high-heeled shoes.

Drivers shall continue to comply with the requirements of Rule 141 until such time as they leave their automobiles.

**Part 5—Wheels and Tyres**

*The following requirements and parameters apply to all competitions.*

**1. RIM WIDTH:**

**1st Category—Racing Cars**

**2nd Category—Group A (Sports Cars) and cars complying with Clubman Formula.**

Where a steel centre is employed, the width of any rim attached thereto shall not exceed the following:

Cars up to 2,000 cc. capacity—and Clubman—215 mm (8½ in.).

Cars over 2,000 cc. capacity—250 mm (10 in.).

Otherwise unrestricted.

**2. 2nd Category Group B (Sports Sedans)  
3rd Category Group C (Touring Cars)**

- (a) Where a steel wheel centre supplied by a vehicle manufacturer as original vehicle equipment is employed, any rim attached to such centre shall not be more than 50 mm (2 in.), wider than the rim originally fitted to such centre.
- (b) Wheels and steel centres other than those supplied by a vehicle manufacturer as original vehicle equipment may not be widened.
- (c) The absolute maximum rim width, regardless of wheel construction shall be 10"

**3. TYRES:**

- .1 Tyres fitted to all rims shall be in accordance with the Tyre and Rim Association recommendations.
- .2 Tyres not listed in the Tyre and Rim Association Manual are to be subject to certification by the manufacturer as being suitable for the rim width concerned.

**4. WET WEATHER TYRES:**

- .1 As most un treaded racing tyres are not suited for other than dry tracks, scrutineers must ensure that (for circuit rces and tarmac rally stages):
  - (a) On wet days only suitable tyres are used; this will exclude specialised dry tyres, unless they have been suitably modified.
  - (b) Tyres used are suitable for the weather and track conditions relative to the car's potential.
  - (c) That all tyres used or likely to be used are scrutinised (competitors too, must ensure that this is done).
  - (d) By checking, in the marshalling area, that late changes have not been made which render the cars unsuitable for use.
- .2 Clerks of the Course will, after consultation with the Stewards and at an appropriate time announce that "un treaded tyres are not to be used until further notice".
- .3 Championship and long distance races will be subject to special decisions. If a specific order is to be made, it will be that the race will commence on treaded tyres, Competitors would thereafter be free to change. This order will be made in respect of those races if—
  - (a) It is raining at the start, and the track is wet, or
  - (b) It is not raining at the start, but the track is "running" with water over the greater part of its length.
- .4 In Formulae where a specific dry weather tyre and/or wet weather tyre are specified, the wet weather tyre may be used only under conditions (a) and (b) in paragraph 3 above.

**NOTES;**

For wheel and tyre restrictions to 4th and 5th Category vehicles, see relevant sections of Group regulations.

**MAXIMUM PERMISSIBLE RIM WIDTHS**

| Category | Group  | Maximum Widening Permitted |                        | Max. Rim Width for Steel Wheels    | Maximum Rim Width other than Steel Wheels |
|----------|--------|----------------------------|------------------------|------------------------------------|---|
|          |        | Prod. Steel Wheels         | Non-Prod. Steel Wheels |                                    |   |
| 1        | Racing | Unrestricted               | None                   | 8½" up to 2 000;<br>10" over 2 000 | Unrestricted                              |
| 2        | A      | Unrestricted               | None                   | "                                  | "   |
| 2        | B      | 50 mm (2 in.)              | "                      | "                                  | 10"                                       |
| 3        | C      | 50 mm (2 in.)              | "                      | "                                  | "   |
| Clubman  | —      | Unrestricted               | None                   | 8½"                                | Unrestricted                              |

## Part 6—Aerofoils and Coachwork

The following are the CAMS (and F.I.A.) parameters regarding the fitting of aerofoils and other aerodynamic devices to cars.

1. For all vehicles (1st, 2nd, 3rd, 4th and 5th Categories) coachwork shall be deemed to include all external parts of the car which extend above the highest point of either the front or rear wheels (with tyres) with the exception of units definitely associated with the functioning of the engine or transmission and the roll bar.

Any specific part of the car which has an aerodynamic influence on the stability of the vehicle must be mounted on the entirely sprung part of the car and shall be firmly fixed whilst the car is in motion.

Neither the roll bar nor any of the units associated with the functioning of the engine or transmission shall have an aerodynamic effect by creating vertical thrust.

All external projections swinging in a horizontal plane shall have a minimum radius of 15 mm. The leading edge of any aerofoil fixed to the front of the car shall not be sharp.

Switches for battery isolation & fire fighting equipment may project beyond the coachwork without impinging regulations.

2. 2nd Category vehicles shall comply with the following requirements, (except for cars which comply with Group B Reg. 3.12 or Group D Reg. 3.11), viz: the highest point of any forward-facing gap in the coachwork shall not be situated above a horizontal plane 800 mm above the lowest point of the entirely sprung structure of the car. The maximum width of the coachwork shall not exceed by more than 200 mm the maximum width between the two vertical planes tangent to the outer face of the front/rear wheels.

3. 1st Category vehicles shall comply with the following requirements:

- .1 No element of coachwork may exceed in height a horizontal plane situated at 900 mm above the ground. Neither the roll bar nor any of the units associated with the functioning of the engine shall be included. Measurements are to be taken with the driver on board.
- .2 Cars of a type registered at 1 Jan 1975, but constructed after 1 July 1975; and cars of a type not registered at 1 Jan 1975, but constructed after 1 Jan 1976; and cars registered at 1 Jan 1975, but which have subsequently been substantially varied; must all comply with the following requirements, viz:

|   | F1      | F2                  | FF     |
|---|---------|---------------------|--------|
| Maximum width ahead of front wheels                             | 1500 mm | 1500 mm             | 950 mm |
| Maximum width ahead of front wheels, above height of wheel rims | 1100 mm | 1100 mm             | 950 mm |
| Maximum width between front and rear wheels+ deformable         |         | 1100 mm +<br>200 mm | 950 mm |

|                                  |         |         |         |
|----------------------------------|---------|---------|---------|
| F/Pacific absolute maximum       | 1300 mm |         |         |
| Maximum width behind rear wheels | 1100 mm | 1100 mm | 1100 mm |

.3

|  | F/Pacific | Others |
|--|-----------|--------|
| Front overhang, max                            | 100 cm    | —      |
| Rear overhang, max (from centre of wheel/axle) | 80 cm     | 100 cm |

- .4 The minimum weight is that of the car in running order, i.e. with all lubrication and cooling liquids but without fuel. The ballast which is prohibited is that of a removable type. It is therefore permissible to complete the weight of the car through one or several ballasts incorporated to the materials of the car provided that solid and unitary blocks are used, and that they are fixed by means of a tool and offer the opportunity of being sealed on should the officials entrusted with the scrutineering of the car deem it necessary.
- .5 Wheels shall be external to the coachwork.
- .6 The coachwork opening giving access to the cockpit must have the following minimal dimensions:—  
Length: 600 mm  
Width: 450 mm, maintained over 300 mm from the most rearward point of the seat backrest towards the front.
- .7 Driver's seat able to be entered or left without it being necessary to open a door or remove a panel. Sitting at his steering wheel the driver must be facing forwards. Moreover, the cockpit must be so conceived that the maximum time necessary for the driver to get out does not exceed 5 seconds.

## Part 7—Commercial Fuel

"Commercial fuel" is defined by the CAMS as:

### 1. FOR ALL SPARK-IGNITION ENGINES (RECIPROCATING AND ROTARY):

Either a "motor" fuel produced by an oil company and currently distributed at roadside refuelling stations throughout the territory of CAMS. This shall include the normal "premium" or "super" and "regular" motor fuels and may include any of the "super premium" or "high aromatic" fuels (e.g. "Toluol" or "methylbenzene") available at some refuelling stations; or gasoline complying with the recognised specification for 100/130 AVGAS, produced by an oil company and currently distributed for commercial use throughout the territory of the CAMS.

- (a) In all events in which the use of commercial fuel is mandatory such fuel must contain a maximum of 2% oxygen and 1% nitrogen by weight; the remainder of the fuel consisting exclusively of hydrocarbons and not containing any alcohols, nitro compounds or other power boosting additives. Only air may be mixed with the fuel as an oxygen.
- (b) Should a commercial fuel, of higher octane rating than is marketed at the date of the publication of these Rules be produced, the oil company producing such fuel shall give notice to the CAMS by registered letter; such fuel, or its equivalent, may thereafter be used from a date 30 days after the mailing of such registered letter.
- (c) Suppliers of fuel to entrants in any competition shall be required to send

to the CAMS samples of such fuel at such times and in such quantities as the CAMS may decide, together with a declaration that such fuel complies with these Rules.

- (d) Nothing in the foregoing shall be deemed to prohibit the addition of water or a lubricant which does not increase the octane rating or specific heat content of the fuel.

N.B. Any other gasoline or petrol (e.g. Avgas 115/145) of higher rating than that specified is NOT permitted when "commercial fuel" is specified.

### 2. FOR COMPRESSION-IGNITION ENGINES (RECIPROCATING OR ROTARY):

A hydrocarbon product derived from petroleum, and conforming with British Standard 2869:1970 Class A1, with the exception of cloud point. The only permissible additive treatments shall be oxidation or corrosion control or lubricity. Additives to improve the ignition quality of the fuel are not permitted.

### 3. FOR TURBINE ENGINES:

Kerosine used by commercial aviation companies for turbo-propellor or jet engines.

## Part 8—Fire Extinguishers

1. All racing cars of Formula 1 and Formula 2 when competing in circuit races only, shall be required to be fitted with a fire-extinguishing system of at least 5 kg extinguishing capacity, at least half of which must be placed forward of the engine, but aft of (i.e. to the rear of) the foremost pick-up points of the front suspension.

The system must include a manual triggering device, operable by the driver on board or by a helper outside the vehicle, and the location of which must be indicated by a letter E in a red circle. The direction of the outlet/s of the extinguishant is free.

The operating system must be designed so that even if the battery of the car is inoperative, the extinguisher will still function.

2. In other than circuit races, all cars mentioned in .1 (above) and in all competitions, all other Category 1 vehicles, must be equipped with at least a fire extinguisher as required in .3 (below).
3. All vehicles of the 2nd, 3rd, 4th and 5th Categories in all speed events must be equipped with a fire extinguisher which complies with the following conditions and is properly fitted at a suitable location:
  - (a) it must comply with either of the Australian Standard 1846 or 1848;
  - (b) it must be of at least 900 g capacity;

The fitment of a CAMS-approved "on-board" extinguishing system shall be acceptable as an alternative to the fitment of a separate extinguisher.

## Part 9—Safety Harness

1. Safety harness shall comply at least with the requirements of AS E35 and must be fitted and worn by the driver.
2. In all vehicles in which a roll bar/cage is required to be fitted, there shall be fitted a full harness, consisting of at least a lap strap and two-strap shoulder harness, fitted with a single buckle, and of which each component complies at least with the requirements of AS E35. The harness must be securely mounted at at least three points; the shoulder straps mounted behind the driver must be above a line drawn downward from the shoulder at an angle of 40° to the horizontal. If the two shoulder straps join prior to a common mounting point then that junction shall be at least 150 mm behind the driver's neck.
3. In closed cars which are not required to be fitted with a roll bar or cage, a seat belt of the full harness type (as described in .2), or a lap-sash type, must be fitted and worn by the driver. Each component must comply at least with ASE35.
4. In all cases of mounting the following must be observed:
  - (a) Floor mounting must be reinforced with a plate of at least 75 mm x 50 mm on the underside of the body.
  - (b) Full harness rear mounting points must be to a substantial part of the vehicle's structure, reinforced as may be appropriate.
  - (c) On production cars, the original mounting points may be satisfactory.

## Part 10—Roll Over Protection

## 1. ROLL OVER PROTECTION IS REQUIRED AS FOLLOWS:

- .1 Race Meetings—all cars, except competition exclusively for 5th Category (Historic) cars other than Group N.
- .2 Open Speed Events—all cars, except those of Group C, of 5th category, or those which are road-registered.
- .3 Closed Speed Events—not required.
- .4 Other Events—as stipulated in the relevant Supplementary Regulations.
- .5 Events other than International and National open race meetings—not required on bodily unmodified fixed roof closed cars.

## 2. CONFIGURATION:

- .1 The *general design* and form of the Protection shall be as shown in Section 3 hereof.
- .2 The *hoop* should be placed behind and above the driver's head from one side of the car to the other, and with the driver seated in the normal position, the hoop shall:
  - (a) be of a height not less than 50 mm above the driver's helmet;
  - (b) in conjunction with the vehicle's structure not leave unprotected any part of the driver's profile, including shoulders when viewed from the front or rear;
  - (c) not overhang, but be within 150 mm of the driver's helmet;
  - (d) in closed cars, be placed as near as possible to the roof in order to limit its crushing in the event of a somersault.
  - (e) in 1st Category (Racing) Cars, be constructed so that the driver's helmet is prevented from passing between the hoop bars to the extent that the helmet is visible at the rear of the hoop when viewed from the side.
- .3 (a) *Braces* shall be straight, save that in closed cars where the diameter of the brace material is 45 mm (1 $\frac{3}{4}$ " or more, they may be bent to conform to a coachwork profile, e.g. roof line.
  - (b) A *transverse* diagonal brace, where fitted, shall be attached to the hoop from the bottom of one side to the top of the other side.
  - (c) *Longitudinal* brace/s shall be attached to the upper portion of the hoop on each side of the car where applicable and extend towards the rear of of the car as far as practicable.
- .4 *Front seat access* must not suffer interference by the fitting of roll over protection and no encroachment upon the volume reserved for the driver and front seat passenger is permitted.
- .5 Rear passenger space may be encroached upon by the elements of roll over protection and elements may pass through rear seat upholstery.

*Note: Forward Facing Struts—Alternatives*

On 1st Category cars, it may be more appropriate for the longitudinal braces to be forward rather than rearward. In such cases, these may be approved subject to accessibility to the driver not being impaired. Similarly, in open sports cars, the same may apply. In the case of Sports Cars, prior approval of CAMS is necessary.

## 3. FORMS OF ROLL OVER PROTECTION ACCEPTABLE

| Type   | Description                | Vehicle Application  | Remarks  |
|--------|----------------------------|--|--|
| Type 1 | Solo Roll Bar              | 1st Category Cars.   | Two 25 mm x 1.5 mm longitudinal braces or one brace of identical size to the hoop. |
|        |                            | Open sports cars only for other than speed events.   |  |
| Type 2 | Full width Roll Bar        | Light weight (700 kg) closed cars and open sports cars.  | Acceptable only for other than speed events and races.                             |
| Type 3 | Full width Braced Roll Bar | Minimum acceptable (speed events) for closed cars under 1150 kg and open sports cars.  |  |
| Type 4 | Half Cage                  | Recommended for closed cars under 1150 kg.<br>Minimum requirement for closed cars over 1150 kg.<br>Recommended for open sports cars.<br>Minimum acceptable for all open cars in Off Road events. | Strut MS may be MQ or NP.  |
| Type 5 | Full Cage                  | Recommended for closed cars over 1150 kg.  | Strut NP may be MQ.  |

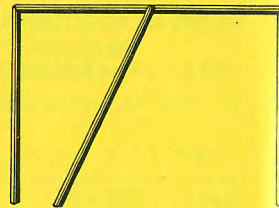
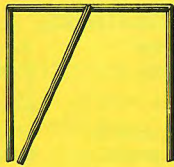
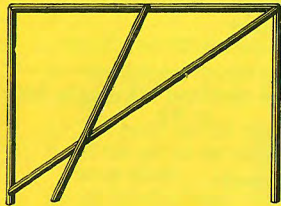
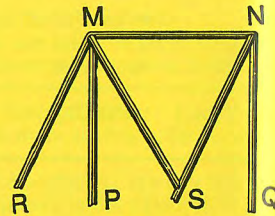
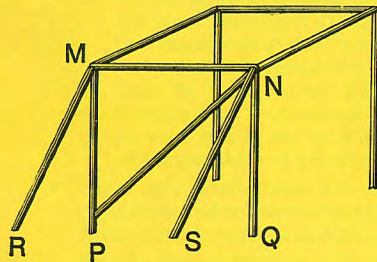
Type 1  
Solo roll barType 2  
Full width roll barType 3  
Full width bracedType 4  
Half-cageType 5  
Full-cage**4. MATERIAL:**

- .1 For *hoops and braces* all steel tube shall be round in section of minimum sizes as set out below, electrical-resistance welded to Australian Standard 1450-1974 ("Circular and Non-Circular Steel Tubes for mechanical and general engineering purposes").
- .2 *Alternative materials* may be used only in protection manufactured by authorised firms or persons, and such protection must bear the manufacturer's name and licence number.
- .3 *Alternative Sections* corresponding to steel tube sections.
 

| <i>Mild Steel</i> | <i>Aluminium Alloy Alternative</i> |
|-------------------|------------------------------------|
|                   | (i) B6351 T5                       |
|                   | (ii) B6061 T6                      |
| mm                | mm                                 |
| 25 x 1.5          | 30 x 2.0                           |
| 30 x 1.5          | 38 x 2.5                           |
| 38 x 2.5          |                                    |
| 45 x 2.5          | 45 x 3.0                           |
| 50 x 2.5          | 50 x 3.0                           |
- .4 *Bolts* shall be either Grade 5 (55 ton) High Tensile hexagon headed bolts or 90 ton cap screws (see Fig. 1).
- .5 *Pins* for removable connections shall be either 55 ton High Tensile steel or 90 ton Cap Screws.

**5. FABRICATION:**

- .1 One continuous length of tubing should be used for the main structure with smooth continuous bends and no evidence of crimping, wall failure or significant section weakening.
- .2 All *welding* should be of the highest quality possible with full penetration preferably arc welding and in particular heliarc).
- .3 Any *holes* drilled in the main hoop shall conform with Fig 2 below. The wall thickness of the inserted tube shall be equal to or greater than the drilled tube.
- .4 *Holes* drilled in a brace shall conform with Fig 3 below unless the wall thickness of this brace is equal to or greater than 30 mm (10 gauge). The wall thickness of the inserted tube shall be equal to or greater than the drilled tube.

**6. REMOVABLE CONNECTIONS:**

In cases where removable connections are used in roll-over protection construction they must be one of the following approved types.

1. Tapered connection (see Fig. 5)
2. A twin lug connection with axis working under double shearing conditions (see Fig 4)
3. A muff connection (see Fig. 7)
4. A tee clamp connection (see Fig. 6)

**7. MOUNTINGS:**

- .1 *Plates* of the following dimensions affixed to a structural portion of the car are required, when the mountings are not part of the car's structure.

|                   |           |        |         |
|-------------------|-----------|--------|---------|
| <i>Thickness:</i> | Aluminium | 6.4 mm | (¼")    |
|                   | Steel     | 4.7 mm | (3/16") |

Area: Lower: 100 mm x 45 mm (4" x 1")  
 Upper: Where the car's weight is less than 700 kg:  
 100 mm x 65 mm  
 between 700 kg-1150 kg 100 mm x 75 mm  
 greater than 1150 kg 100 mm x 100 mm

- .3 **Bolts:** At least 2 of 10 mm ( $\frac{3}{8}$ ") diameter or 3 of 8 mm ( $\frac{5}{16}$ ") diameter, or the approved equivalent thereof.
- .4 **Chassis Reinforcement.** Where the roll bar rests on a boxed section the latter must be locally reinforced. A recommended method is shown in Fig. 5.
- .5 **Road Registered Production Closed Vehicles.**  
 (a) The hoop may be mounted utilising a minimum of 4 safety belt mounting points provided by the vehicle manufacturer, provided that—  
 (i) the mounting points are within 75 mm of the centre line of the hoop tube, and  
 (ii) the intermediate mounting plates are as specified in .1 above for upper plates.  
 (b) The braces may use the rear safety belt mounting points provided by the vehicle manufacturer.

**8. DIMENSIONS:**

- .1 For the main hoop the minimum sectional dimensions are as follows:
- |  |                             |
|--|-----------------------------|
| <i>Hoop Size</i>                       | <i>Tube Section (Steel)</i> |
| Less than 610 mm x 380 mm              | 30 mm x 1.5 mm              |
| Off Road Vehicles of up to 700 kg mass | 38 mm x 2.5 mm              |
| All others                             | 45 mm x 2.5 mm              |
- .2 Bracing Material shall be not less than—  
 (a) Types 1 and 2 25 mm x 1.5 mm  
 (b) Types 3, 4 and 5 cars less than 1150 kg: 30 mm x 1.5 mm  
 cars above 1150 kg: 45 mm x 1.5 mm

**9. IMPLEMENTATION:**

The foregoing revised requirements came into effect on 1st January 1980 for all cars first registered with CAMS after that date. Pre-existing cars must comply with the requirements effective until 31st December 1979.

10. The above requirements serve to specify a minimum standard only. Alternative configurations will be considered by CAMS on individual application.

11. Roll bars which do not comply with these regulations or are not otherwise specifically approved (see Reg. 10) are prohibited.

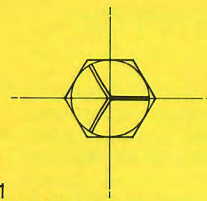

Fig 1 Bolt Identification  
 Grade 5 Head Marking.  
 U.T.S. 536 TON/in.<sup>2</sup>  
 Threads to A.S. B18.2.

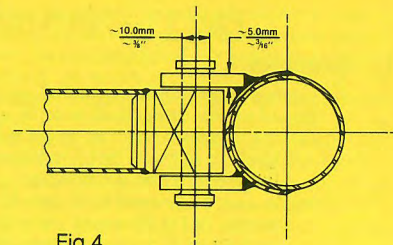

Fig 4 Twin Lug Connection

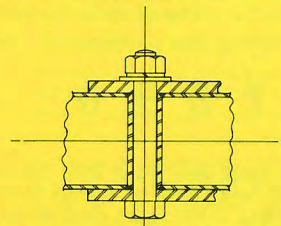

Fig 2 Method of Reinforcing a Box Section

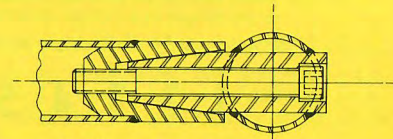

Fig 5 Tapered Connection

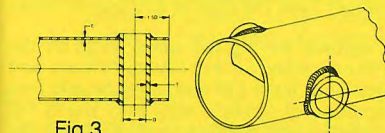

Fig 3 Method of Sleeving a Hoop or Brace

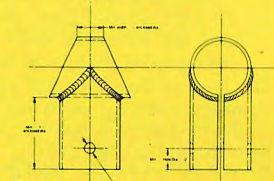

Fig 6 Mat'l & Wall Thickness.  
 Mild Steel; 3.0 mm min.  
 CAMS Approved Alloys only.  
 Alloy Welding: 5% Magnesium Filler Rod

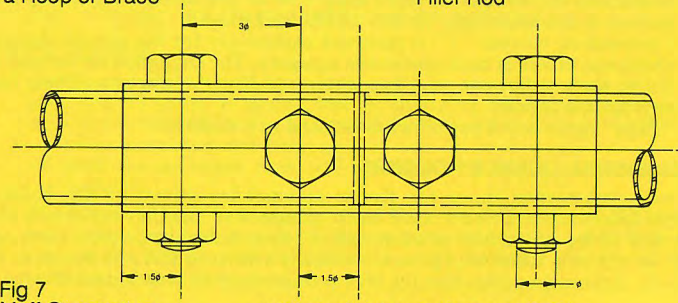

Fig 7 Muff Connection

12.0 mm (Tube < 40.0 mm O.D.)  
 14.0 mm (Tube < 40.0 mm < 50.0 mm O.D.)  
 16.0 mm (Tube < 50.0 mm O.D.)

## Part 11—Markings on Automobiles

### 1. NUMBERS:

- .1 Competition numbers carried on automobiles in accordance with Rule 147 in Speed competition shall comply with the following requirements:
  - (a) the number shall be required to be carried in such manner that in the opinion of the Chief Timekeeper it is clearly visible from both sides and the front of the automobile;
  - (b) in cars of Groups B, C, and E, the number must be displayed on the front doors. In 1st Category cars, the number must be displayed alongside the cockpit or if physically possible, on the end plates of the rear wing;
  - (c) the number shall be either white on a black background or black on a white background. The background for the number must be either a disc or rectangle in a colour contrasting with the colour of the coachwork.
- .2 Numbers must be of the style known as "Tempo heavy condensed," viz—

**1 2 3 4 5 6 7 8 9 0**

- (a) on other than 1st Category cars, each figure must be at least 280 mm in height, and the width of the line in each figure must be at least 50 mm;
- (b) on 1st Category cars, the minimum height of the figure shall be 230 mm and the minimum width of the line in each figure at least 40 mm. The background shall be at least 450 mm wide by 330 mm high.
- .3 No part of any numeral shall be closer than 40 mm to any part of the adjoining numeral, or to any part of the edge of the background; and no part of the competition number shall be closer than 160 mm to any part of other signs permitted hereunder.
- .4 Above or below the background, a surface having the same width as the background (in any case at least 450 mm wide on 1st Category cars and 500 mm on other cars), and of a height of at least 120 mm, shall be left free of advertising to be used at the discretion of CAMS, who may use it for advertising purposes, or who may delegate to the organisers authority to use that space. On cars on which such an area is not available, due to coachwork limitations the competitor shall keep free of any advertising an equivalent surface in the immediate vicinity of the background.
- .5 Competition number "1" is reserved exclusively for the current Australian champion driver in each applicable category. The champion driver may elect not to use number one, and in such eventuality it would be withheld for the appropriate period.
- .6 "Zero" alone is not permitted to be used as a number.

### 2. PROVISIONAL LICENCE HOLDERS:

In any race (other than those for Karts) automobiles driven by the holders of Provisional Licences for Drivers, shall carry, mounted so that they are clearly visible from the rear of the automobile at a distance of 100 m in daylight, a plate carrying the capital P, in red on a white background, basically similar in size and design to those approved by Australian authorities for civil probationary or provisional drivers.

### 3. OTHER SIGNS:

- .1 Signs or advertisements displayed upon automobiles in accordance with Rule 155 shall comply with the following requirements:

- (a) No sign or advertisement shall be permitted on any windscreen, side or rear window, or, other than the competition number, above a line joining the upper level of each of these. Notwithstanding the provisions of this sub-paragraph, it shall be permitted on series production based cars the windscreens of which are of original dimensions, to place a sign, on the windscreen, indicating the make of the vehicle, or the model of the vehicle, or the driver's name, or the name of an affiliated or associated car club, or in the case of cars of Group G, the drivers' and navigators' names; provided that such sign does not extend downwards for more than 25% of the depth of the windscreen from the upper edge thereof, save that no part of the sign may be more than 100 mm below the top level of the windscreen.
- (b) No sign or advertisement shall be permitted within 100 mm of the background area of a competition number, or within 160 mm of the number itself.

- .2 No slogan, or any sign containing a verb or verbal phrase, shall be permitted.
- .3 No sign shall be permitted to contain any Arabic numerals, unless such sign comprises the name of a Club affiliated or associated with CAMS; or forms part of a registered trade mark; or being a telephone number is displayed on a rearward facing coachwork panel.
- .4 No sign or advertisement shall be permitted to be indecent or in breach of good taste; the Clerk of the Course at any meeting shall be authorised to refer to the Stewards any sign which he deems to be contrary to the requirements of this paragraph and the Stewards' decision thereon shall be final in respect of that meeting.
- .5 Registration labels and official number-plates shall not be deemed to be advertising with regard to this Appendix.
- .6 In International competitions, there shall be displayed on both front mudguards a facsimile of the national flag of the driver/drivers, as well as the names of the drivers. The minimum height of both flags and names shall be 40 mm.

### 4. LETTERINGS:

The lettering of all numerals and letters in all signs referred to in this Appendix and these Rules shall be carried out in a neat, regular and professional manner; scrutineers may order the relettering of any sign or part of a sign, etc., which, in their opinion fails to comply with the requirements of this paragraph.

### 5. TRADE MARKS:

- .1 Arabic numerals where they form part of a registered trade mark may be used subject to the foregoing, and the following additional requirements:
  - (a) On the sides of the car no part of the numeral shall come within 120 mm of a competition number;
  - (b) shall be no larger than and a contrasting colour to the competition number;
- .2 The above notwithstanding, the chief timekeeper may direct the removal of such numbers from the side of the car presented to the timing box, if in his opinion the presence of the numerals could prejudice the operation of the timing and lap scoring.

### 6. SPONSOR REQUIREMENTS:

- .1 In all races, sponsors may make no requirements or prohibitions (regarding signs) binding on entrants.

## ROLL BARS

- .2 In rallies of championship status only, sponsors may require the reservation of the front doors only for advertising matter, but may make no other restrictions.

### 7. VARIATION:

Notwithstanding the requirements of this part of Appendix C, the Chief Executive Officer of CAMS shall have discretion in approving any sign not in conformity therewith, provided it is deemed to be a public service and/or beneficial to the sport; and in respect of numbers, on condition that artwork of the proposal is submitted, and if permitted, that a fee of \$500 be paid.

